

Crystal Air AMC 1108 Instructions

AMC 1108 Usage instructions

When using an ozone monitor we must remember that ozone is one of the hardest gasses to detect because it is so reactive. Being so reactive the ozone depletes very easily, especially with heat or when put thru a fabric or mesh of any kind. Because of the reactivity and easy depletion of ozone it is very important to provide a fresh sample of ozone rich air to the sensor, this can be achieved in one of a few ways as follows:

1. To test the ambient ozone levels in a room that is safe to enter, wave the monitor vigorously in the air until the reading stops changing.
2. To test the levels of ozone in an air flow place the ozone monitor in the path of air where it gets it's highest reading but does not restrict the flow of air. Restricting the flow of air will usually change the concentration of ozone in the sample gas.
3. When testing ozone levels in a room that is not safe to enter due to high ozone levels the "AMC 1108/remote sensor" should be used. The remote sensor model has a 20 foot wire between the sensor and the hand held digital display and can be disconnected at the display. The Sensor head should be placed in the room with a small fan supplying the fresh gas sample to the sensor head.



1 WARRANTY

The AMC-1100 series gas monitor is warranted against defects in material and workmanship for a period of one (1) year from date of shipment. During the warranty period, The / Monitoring Corporation will repair or replace components that prove to be defective in the opinion of AMC. We are not liable for auxiliary interfaced equipment, or consequential damage. This warranty shall not apply to any product, which has been modified in any way, which has been repaired by any other party other than a qualified technician or authorized AMC representative, or when such failure is due to misuse or conditions of use.

1.1 LIABILITY

All AMC products must be installed and maintained according to instructions. Only qualified technicians should install and maintain the equipment. AMC shall have no liability arising from auxiliary interfaced equipment, for consequential damage, or the installation and operation of this equipment. AMC shall have no liability for labour or freight costs, or any other costs or charges in excess of the amount of the invoice for the products.

THIS WARRANTY IS IN LIEU OF ALL OTHER WARRANTIES, EXPRESSED OR IMPLIED, AND SPECIFICALLY THE WARRANTIES OF MERCHANTABILITY AND FITNESS FOR A PARTICULAR PURPOSE. THERE ARE NO WARRANTIES THAT EXTEND BEYOND THE DESCRIPTION ON THE FACE THEREOF.

Read this manual carefully, as the purchaser is entirely responsible for installation and operation.

1.2 MODIFICATIONS AND SUBSTITUTIONS

Due to an ongoing development program, AMC reserves the right to substitute components and change specifications at any time without incurring any obligations.

1.3 PRODUCT RETURN

All products returned for warranty service will be by prepaid freight and they will only be accepted with a repair number issued by AMC. All products returned to the client will be freight collect.

WARNING

<p>USING ELECTRICALLY OPERATED EQUIPMENT NEAR GASOLINE, OR GASOLINE VAPOURS MAY RESULT IN FIRE OR EXPLOSION, CAUSING PERSONAL INJURY AND PROPERTY DAMAGE. CHECK TO ASSURE THE WORKING AREA IS FREE FROM SUCH HAZARDS DURING INSTALLATION OR WHEN PERFORMING MAINTENANCE, AND USE PROPER PRECAUTIONS.</p>



AMC-1100 Portable Trace Gas Monitor

2 PRODUCT INFORMATION

Monitor Part Number AMC-1108-SE3

Monitor Serial Number

Sensor Warranty Period 1 year

Power Supply Requirement:

- Internal Battery (see note) 9 VDC, ALKALINE
- Typical Battery Life (non-alarm) 500 hours
- External DC Supply 12 to 24 VDC

Operating Temperature 0 to 40°C

Recorder Output Range 0 to 1 VDC

Certification CSA C-22.2 #0-M198 & #157-M1987
(CO, H₂S, SO₂, NO₂, Cl₂, HCN)

Sensor		Type of Gas	Range	Alarms	
Part No.	Ser. No.			Low	High
		OZONE	0.01-9.99 PPM		

Note:

For proper operation, use only 9V ALKALINE battery (Duracell MN1604 or equivalent).

Note:

All Monitoring systems must be installed and maintained according to instructions, to ensure proper operation. Only qualified technicians should install and maintain the equipment.



3 PRODUCT DESCRIPTION

3.1 GENERAL DESCRIPTION

The AMC-1100 series gas monitor is a portable hand-held instrument designed to continuously or intermittently monitor surrounding air for traces of hazardous gases (see section 2, Product Information). The unit comes with the following features, as shown in Figure 1.

3.1.1 MONITOR SPECIFICATIONS

- | | |
|----------------------------------|----------------------------------------------------------------------------------------------------------------------------------------------------------------------|
| 1. POWER SWITCH | On/off power switch. (when power is on, the digital display is activated) |
| 2. DIGITAL DISPLAY | Meter displays concentration of gas and has a build-in low battery indicator. |
| 3. LED ALARM INDICATOR | A red LED indicates alarm levels of gas.
Flashing: Indicates LOW alarm.
Continuous: Indicates HIGH alarm. |
| 4. AUDIO ALARM INDICATOR | A buzzer indicates alarm levels of gas.
Intermittent: Indicates LOW alarm.
Continuous: Indicates HIGH alarm. |
| 5. ZERO ADJUST (Z) | Calibrates the display to 0 with zero gas. |
| 6. SPAN ADJUST (S) | Calibrates the sensitivity of the display with a known gas mixture. |
| 7. EARPHONE JACK (EAR) | Allows use of an earphone when in a noisy environment. |
| 8. RECORDER JACK (REC) | Provides a 0-1 VDC linear output signal proportional to the gas concentration. It can be connected to any recording or measuring device with a high-impedance input. |
| 9. EXTERNAL POWER JACK (EXT PWR) | Allows the unit to be powered by an external 12-24 VDC power source. |



AMC-1100 Portable Trace Gas Monitor

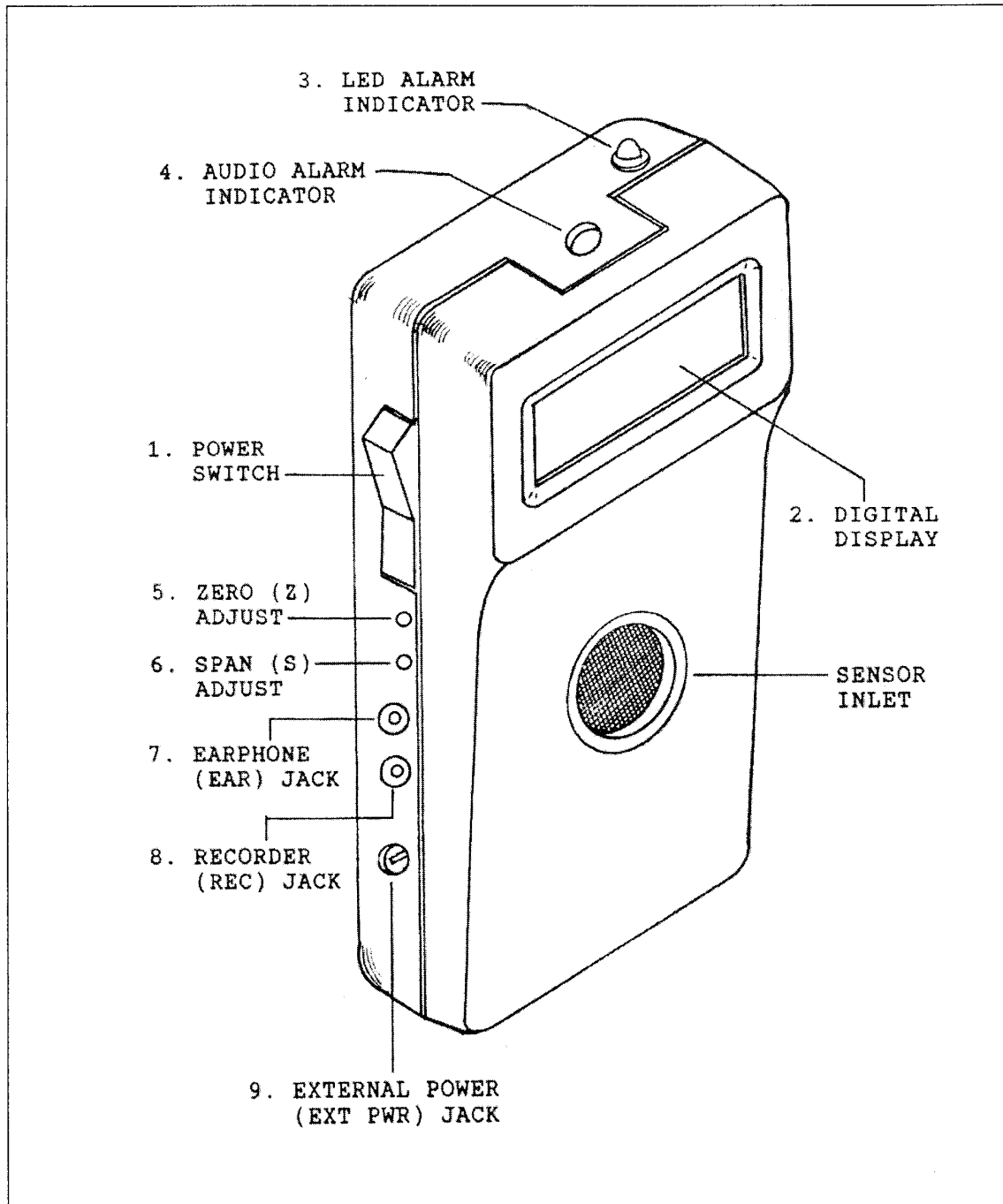



4 OPERATION AND CALIBRATION

4.1 OPERATION

When the unit is switched-on, a reading can be taken after a warm up period of about one minute. Gas concentrations are indicated in PPM on the digital display.

ALARMS: At the LOW alarm level, the LED flashes and the buzzer beeps intermittently.
At the HIGH alarm level, the LED stays lit and the buzzer sounds continuously.

BATTERY: The word "BAT" appears on the display as a warning to replace the battery.

4.2 CALIBRATION

Recalibration is necessary when replacing the sensor. Verification of calibration should be done at least once every 3 months for safety reasons. Weekly testing is recommended for highly demanding applications.

Factory or on-site calibration services, customer training, and/or calibration kits can be provided. Specify the sensor type and gas when requesting any of the above.

CAUTION:

<p>Only qualified personnel should perform the actual calibration. Contact the factory for any specific inquiries regarding calibration or operation.</p>

4.2.1 ADJUSTMENTS

For the following procedures, the calibration adapter must be inserted into the sensor opening. The only adjustments required for full recalibration are Zero and Span (refer to Figure 2).

NOTE: Clockwise adjustment will increase the display reading.

Zero: When there is no gas present (clean air or zero gas), the digital display should read 0. Attach the two zeroing plugs to the calibration adapter and wait for the display reading to stabilize, then adjust the zero (Z) trimmer. Remove the zeroing plugs when finished.

Span: To adjust the sensitivity of the sensor, connect the hose from the cylinder to the calibration adapter, open the regulator valve to expose the sensor to the calibration gas sample, then adjust the span (S) trimmer until the displayed value matches the gas concentration applied.



5 PREVENTIVE MAINTENANCE

5.1 GENERAL

The portable monitor unit should be brushed or wiped clean once a year or more, depending on the accumulation rate of dust or dirt. To avoid sensor damage, the unit **MUST NOT** be submerged in any liquid. Hosing or splashing the unit with any liquid must also be avoided.

5.2 VERIFICATION OF OPERATION

To verify the operation of the portable monitor unit ensure that it is still responding to gas. This test should be performed every few months but for more demanding applications verification should be performed on a weekly basis.

5.3 SENSOR REPLACEMENT

If the display reading is erratic or unusually low when the unit is exposed to gas, the sensor should be replaced. To replace the sensor, refer to Figure 3 for procedure and assembly order.